

Features

- International standard package
With DBC ceramic base plate
- Planar passivated chips
- Short recovery time
- Low switching losses
- Ultra-soft recovery behaviour
- Industry standard package
- UL recognition pending

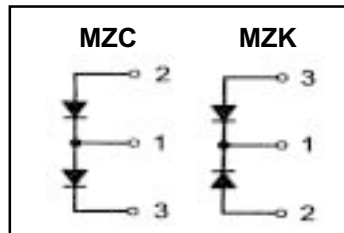

<p>V_{RRM} = 600V I_{FAV} = 100A t_{rr} = 250ns</p>
--

Benefits

- Antiparallel diode for high frequency switching devices
- Increased operating efficiency
- Direct mounting to heatsink
- Uninterruptible power supplies (UPS)
- Ultrasonic cleaners and welders
- Low voltage peaks for reduced protection circuits

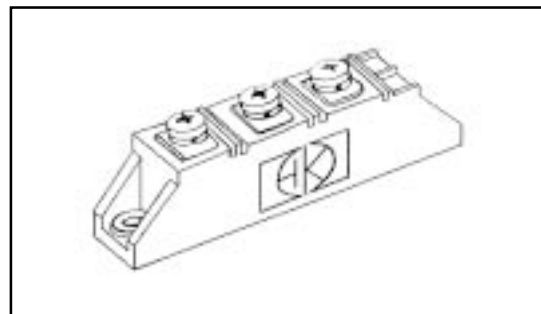

Absolute Maximum Ratings

Symbol	Test Conditions	Max.	Units
V _{RSM} & V _{RRM}		600	V
I _{FRMS}	T _C =75 °C	150	A
I _{FAV}	T _C =75 °C; rectangular, d=0.5	100	A
I _{FRM}	t _p <10μs; rep. rating, pulse width limited by T _{VJM}	TBD	A
I _{FSM}	T _{VJ} =45 °C; t=10ms (50 Hz),sine	1200	A
	t=8.3ms (60 Hz),sine	1300	A
	T _{VJ} =150 °C; t=10ms (50 Hz),sine	1080	A
	t=8.3ms (60 Hz),sine	1170	A
I ² t	T _{VJ} =45 °C; t=10ms (50 Hz),sine	7200	A ² s
	t=8.3ms (60 Hz),sine	7100	A ² s
	T _{VJ} =150 °C; t=10ms (50 Hz),sine	5800	A ² s
	t=8.3ms (60 Hz),sine	5700	A ² s
V _{ISOL}	RMS Isolation Voltage, Any Terminal To Case, t=1 min	2500	V
P _D	T _C =25 °C	280	W
T _J	Operating Junction Temperature Range	-40 to +150	°C
T _{STG}	Storage Temperature Range	-40 to +125	

Thermal / Mechanical Characteristics

	Parameter	Typ.	Max.	Units
R θ JS	Thermal Resistance, Junction-to- Sink DC	-	0.530	
R θ JC	Thermal Resistance, Junction-to- Case DC	-	0.450	°C/W
R θ CS	Thermal Resistance, Case-to- Sink- Module	0.08	-	
	Mouting Torque, Case-to-Heatsink	-	4.0	N.m
	Mouting Torque, Case-to-Terminal 1,2 & 3	-	3.0	
	Weight of Module	100	-	g

Electrical Characteristics (unless otherwise specified)

	Parameter	Min.	Typ.	Max.	Units	Conditions
VRRM	Reverse Breakdown Voltage	600	-	-	V	I _R =2mA
I _R	Diode Leaking Current	-	-	2	mA	T _{VJ} =25 °C V _R =VRRM
		-	-	0.5	mA	T _{VJ} =25 °C V _R =0.8VRRM
		-	-	34	mA	T _{VJ} =125 °C V _R =0.8VRRM
V _F	Diode Forward Voltage	-	-	1.36	V	I _F =100A; T _{VJ} =125 °C
		-	-	1.55	V	T _{VJ} = 25 °C
		-	-	2.05	V	I _F =300A; T _{VJ} =125 °C
		-	-	2.09	V	T _{VJ} = 25 °C
V _{TO}	For power-loss calculations only	-	-	1.01	V	
r _T		-	-	2.85	mΩ	
trr@T _{VJ} =100 °C	Diode Reverse Recovery Time	-	250	300	ns	I _F =100A
I _{RM} @T _{VJ} = 25 °C	Diode Peak Reverse Current	-	-	14	A	V _R =300V
I _{RM} @T _{VJ} =100 °C	Diode Peak Reverse Current	-	-	21	A	-di/dt=200A/μs

Case Outline - a-a-pak

