

XI'AN IR-PERI



PRELIMINARY

MZC200TS120U

MZK200TS120U

Fast Recovery Epitaxial Diode INT -A -PAK

Fast™ Speed FRED

**Features**

- International standard package  
With DBC ceramic base plate
- Planar passivated chips
- Short recovery time
- Low switching losses
- Ultra-soft recovery behaviour
- Industry standard package
- UL recognition pending

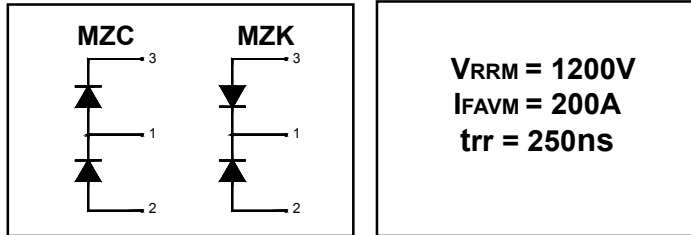

**Benefits**

- Antiparallel diode for high frequency switching devices
- Increased operating efficiency
- Direct mounting to heatsink
- Uninterruptible power supplies (UPS)
- Ultrasonic cleaners and welders
- Low voltage peaks for reduced protection circuits

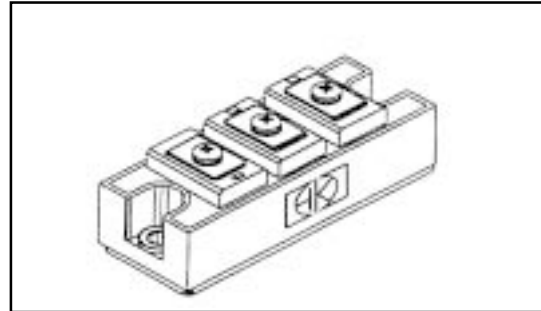

**Absolute Maximum Ratings**

Symbol	Test Conditions	Max.	Units
V <sub>RSM</sub> & V <sub>RRM</sub>		1200	V
I <sub>FRMS</sub>	T <sub>C</sub> =70°C	300	A
I <sub>FAVM</sub>	T <sub>C</sub> =70°C; rectangular, d=0.5	200	A
I <sub>FRM</sub>	t <sub>p</sub> <10µs; rep. rating, pulse width limited by T <sub>VJM</sub>	1000	A
I <sub>FSM</sub>	T <sub>VJ</sub> =45°C; t=10ms (50 Hz),sine	3000	A
	t=8.3ms (60 Hz),sine	3600	A
	T <sub>VJ</sub> =150°C; t=10ms (50 Hz),sine	2700	A
	t=8.3ms (60 Hz),sine	2970	A
I <sup>2</sup> t	T <sub>VJ</sub> =45°C; t=10ms (50 Hz),sine	19900	A <sup>2</sup> s
	t=8.3ms (60 Hz),sine	18000	A <sup>2</sup> s
	T <sub>VJ</sub> =150°C; t=10ms (50 Hz),sine	17200	A <sup>2</sup> s
	t=8.3ms (60 Hz),sine	15300	A <sup>2</sup> s
V <sub>ISOL</sub>	RMS Isolation Voltage, Any Terminal To Case, t=1 min	2500	V
P <sub>D</sub>	T <sub>C</sub> =25°C	700	W
T <sub>J</sub>	Operating Junction Temperature Range	-40 to +150	°C
T <sub>STG</sub>	Storage Temperature Range	-40 to +125	

**Thermal / Mechanical Characteristics**

	Parameter	Typ.	Max.	Units
R <sub>θJS</sub>	Thermal Resistance, Junction-to- Sink DC	-	0.26	
R <sub>θJC</sub>	Thermal Resistance, Junction-to- Case DC	-	0.18	°C/W
R <sub>θCS</sub>	Thermal Resistance, Case-to- Sink- Module	0.08	-	
	Mouting Torque, Case-to-Heatsink	-	4.0	N.m
	Mouting Torque, Case-to-Terminal 1,2 & 3	-	3.0	
	Weight of Module	200	-	g

**Electrical Characteristics (unless otherwise specified)**

	Parameter	Min.	Typ.	Max.	Units	Conditions
V <sub>RRM</sub>	Reverse Breakdown Voltage	1200	-	-	V	I <sub>R</sub> =10mA
I <sub>R</sub>	Diode Leaking Current	-	-	4	mA	T <sub>VJ</sub> =25 °C V <sub>R</sub> =V <sub>RRM</sub>
		-	-	4	mA	T <sub>VJ</sub> =25 °C V <sub>R</sub> =V <sub>RRM</sub>
		-	-	20	mA	T <sub>VJ</sub> =125 °C V <sub>R</sub> =V <sub>RRM</sub>
V <sub>F</sub>	Diode Forward Voltage	-	1.7	1.9	V	I <sub>F</sub> =200A; T <sub>VJ</sub> =125 °C
		-	1.9	2.1	V	T <sub>VJ</sub> = 25 °C
		-	2.3	2.5	V	I <sub>F</sub> =400A; T <sub>VJ</sub> =125 °C
		-	2.5	2.7	V	T <sub>VJ</sub> = 25 °C
V <sub>TO</sub>	For power-loss calculations only	-	-	1.25	V	
r <sub>T</sub>		-	-	3.75	mΩ	
t <sub>rr</sub> @T <sub>VJ</sub> =100 °C	Diode Reverse Recovery Time	-	250	300	ns	I <sub>F</sub> =400A
I <sub>RM</sub> @T <sub>VJ</sub> = 25 °C	Diode Peak Reverse Current	-	-	70	A	V <sub>R</sub> =600V
I <sub>RM</sub> @T <sub>VJ</sub> =100 °C	Diode Peak Reverse Current	-	-	100	A	-di/dt=400A/μs

**Case Outline - int-a-pak**

